



VT7225 Series
Installation Guide
For Modulating Electric Heat Applications
November 2017

Features

- 0 to 10 VDC modulating output
- VDC pulsed modulating output
- VAC pulsed modulating output
- Night setback digital input
- Room or supply control applications

Description

The VT7225 series controllers are microcomputer-based, proportional and integral (PI) devices with one analog 0 to 10 Vdc output, one 8 Vdc and one 24 Vac proportioning pulsed output.

The analog 0 to 10 Vdc modulating output can control the room or supply temperature by modulating directly a 0 to 10 Vdc SCR power controller. The Vdc and Vac pulsed outputs can control the room or supply temperature by modulating directly 4-32 Vdc triggered solid state relays (SSR's) using a time proportioning control algorithm on a 1 second time cycle.

CONTENTS

Installation	3
Location	3
Installation	3
BI 1	5
UI 3	5
Terminal Identification and Function	5
Output Types	6
Wiring	7
Remote sensor accessories	11

INSTALLATION

Remove security screw on bottom of Room Controller cover.

- Open unit by pulling on bottom side of Room Controller (fig. 1).
- Remove wiring terminals from sticker.
- Read FCC ID and IC label installed in the cover.

Location

1. Do not install on outside wall.
2. Do not install in areas exposed to direct heat source.
3. Do not install near an air discharge grill.
4. Do not install in areas exposed to direct sunlight
5. Do not install in areas that restrict vertical air circulation to Room Controller.

Installation

1. Swing open Room Controller PCB to left by pressing PCB locking tabs (fig. 2).
2. Pull out cables 6" out from the wall. Ensure wall surface is flat and clean.
3. Insert cable in central hole of base.
4. Align base and mark location of two mounting holes on wall. Install proper side of base up.
5. Install anchors in wall.
6. Insert screws in mounting holes on each side of base (fig. 2).
7. Gently swing back circuit board on base and push until the tabs lock.
8. Strip each wire 1/4 inch from end.
9. Insert each wire according to wiring diagram.
10. Gently push excess wiring back into hole (fig. 3).
11. Re-Install wiring terminals in their correct locations (fig. 3).
12. Re-install cover (top side first) and gently push extra wire length back into hole in wall.
13. Install security screw.

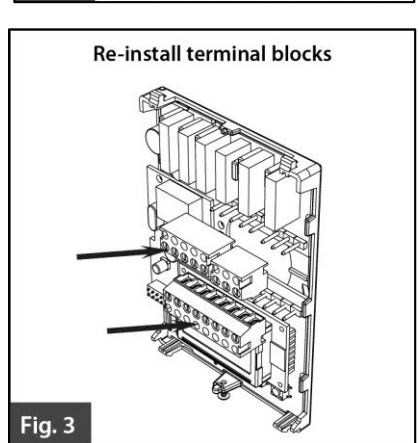
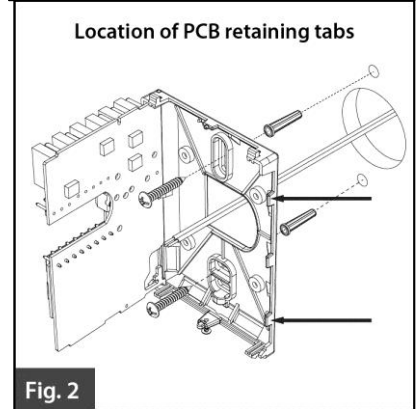
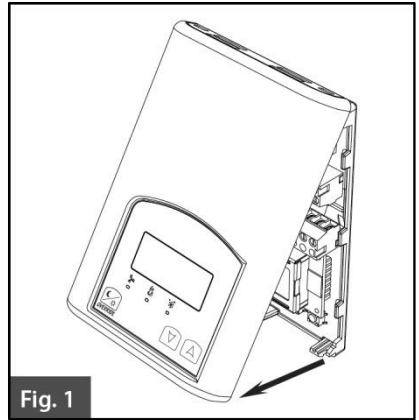



- If replacing an existing Room Controller, label the wires before removal of the Room Controller.
- Electronic controls are static sensitive devices. Discharge yourself properly before manipulating and installing the Room Controller.
- A short circuit or wrong wiring may permanently damage the Room Controller or the equipment.
- All VT7000 series Room Controllers are designed for use as operating controls only and are not safety devices. These instruments have undergone rigorous tests and verification prior to shipping to ensure proper and reliable operation in the field. Whenever a control failure could lead to personal injury and/or loss of property, it becomes the responsibility of the user / installer / electrical system designer to incorporate safety devices (such as relays, flow switch, thermal protections, etc) and/or an alarm system to protect the entire system against such catastrophic failures. Tampering with the devices or unintended application of the devices will result in a void of warranty.

BI 1

Binary input #1 function:

Remote NSB timer clock input. The scheduling will now be set as per the binary input. It provides low cost setback operation via a dry contact:

- Contact opened = Occupied
- Contact closed = Unoccupied

UI 3

Supply air sensor: Used for supply air temperature control.

TERMINAL IDENTIFICATION AND FUNCTION

Pin Number	Pin Identification	Description
4	24 V ~ HOT	Power 24 Vac
5	24 V ~ COM	Common
6		Do not use
7	AUX	24 Vac pulsed output
9	AO 2	0 to 10 Vdc analog output
10	AO 1	8 Vdc pulsed output
12	BI 1	Night setback input
13	RS	Remote sensor
14	S COM	Sensor common
16	UI 3	Supply sensor

Output Types

Type of Output	Controlled Device
Modulating analog 0 to 10 Vdc output	SCR's power controls
Vdc pulsed output	4-32 Vdc triggered SSR's
Vac pulsed output	24 Vac triggered SSR's

Wiring

Supply temperature control with 0 to 10Vdc SCR and override input

By closing contact on BI 1, will force setpoint to « Unocc HT » adjustable inside setup parameters. By adjusting to a low setpoint (ex: 0°F) is a way to disable heating. By adjusting to 180°F, is a way to force maximum heating.

If parameter « MenuScro » = On, will display « Unoccup » when contact closed and « Occupied » when contact open.

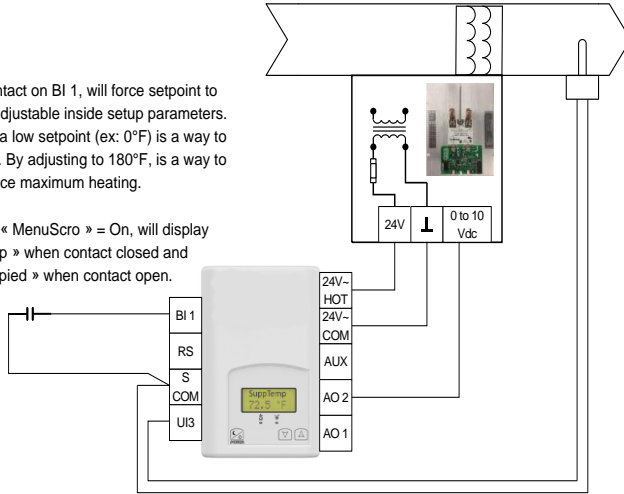

Return temperature control with 0 to 10Vdc SCR

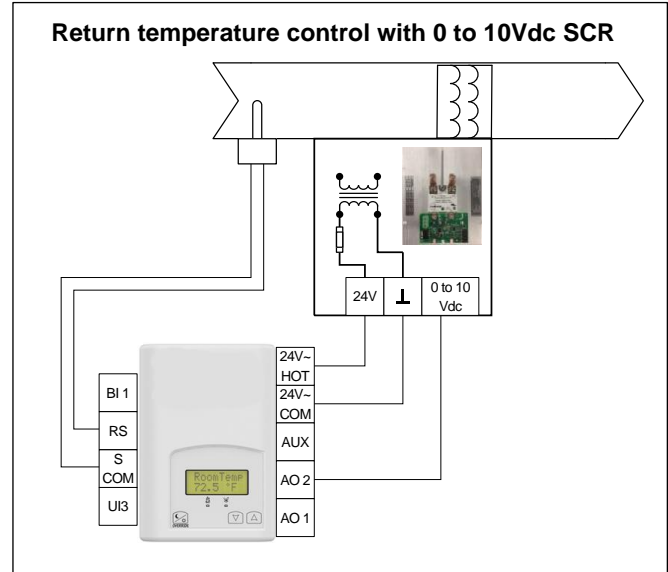

Room temperature control with 4-32Vdc SSR

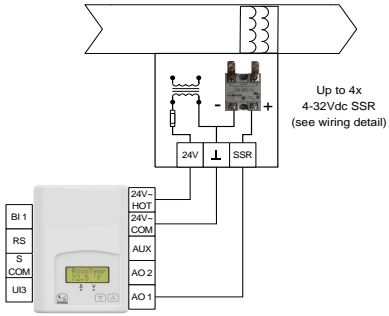

Wiring detail for 4x 4-32 Vdc SSR

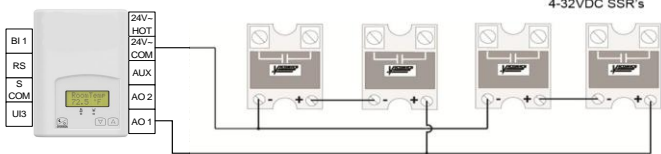

Room temperature control with 4-32Vdc SSR

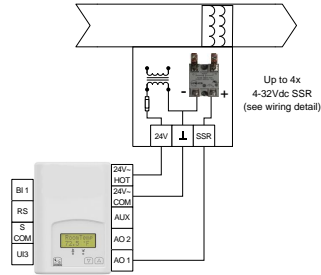

Wiring detail for 4x 4-32 Vdc SSR

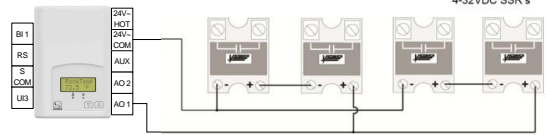

Room temperature control with 24 Vac SSR

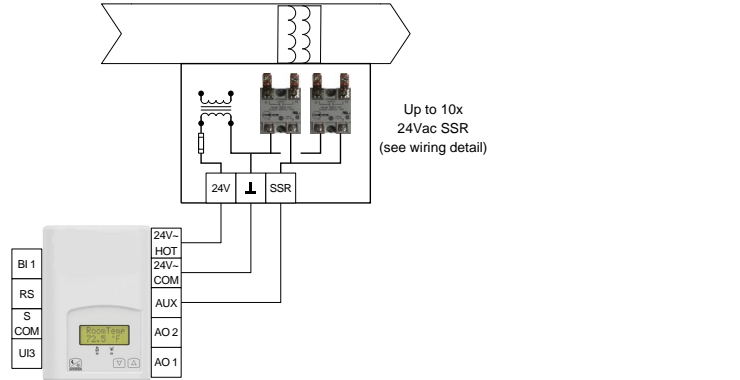



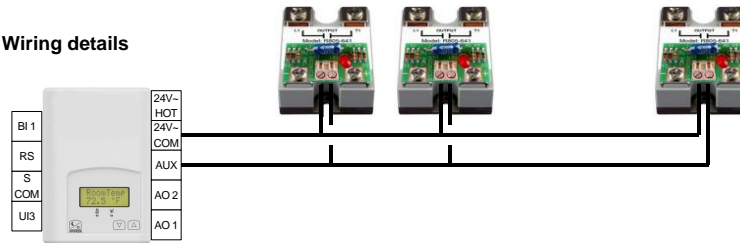

Up to 10x 24Vac SSR in parallel
(or add C24 adapter board to regular 3-32Vdc SSR)

Wiring details



Remote sensor accessories

Model	Description	Application	Picture
S1010E1000	Capsule type sensor for multipurpose use, 1/4" dia. capsule with 65 inch leads	<ul style="list-style-type: none"> Remote sensing easy to dissimulate for indoor and outdoor use Water temperature sensing strapped on pipe or in an immersion well 	
S3010W1000	Room sensor	<ul style="list-style-type: none"> Remote room sensing 3 thermistors with 2 dip switches are provided with each sensor for various averaging combinations 	
S2000D1000	Duct sensor with junction box	<ul style="list-style-type: none"> Remote return air temperature sensing with the sensor mounted on the return air duct. Outside air temperature sensing with the sensor installed in the fresh air plenum. Supply air temperature sensor 	
S1010D1000	Duct Mounted Change Over Sensor	<ul style="list-style-type: none"> Supply duct temperature sensor Return duct temperature sensor Mounting: Through hole in duct, with eyelet 	

Wall mounted sensor

Temperature vs. resistance chart for 10 Kohm Type II NTC thermistor

($R_{25^{\circ}\text{C}} = 10\text{K}\Omega \pm 3\%$, $B_{25/85^{\circ}\text{C}} = 3975\text{K} \pm 1.5\%$)

°C	°F	Kohm	°C	°F	Kohm	°C	°F	Kohm	°C	°F	Kohm	°C	°F	Kohm
-40	-40	324.3197	-20	-4	94.5149	0	32	32.1910	20	68	12.4601	40	104	5.3467
-35	-31	234.4009	-15	5	71.2430	5	41	25.1119	25	77	10.0000	45	113	4.3881
-30	-22	171.3474	-10	14	54.1988	10	50	19.7390	30	86	8.0694	50	122	3.6202
-25	-13	126.6109	-5	23	41.5956	15	59	15.6286	35	95	6.5499	55	131	3.0016

Specifications

Operating Conditions	<ul style="list-style-type: none"> 0°C to 50°C (32°F to 122°F) 0% to 95% R.H. non-condensing
Sensor	Local on board NTC Thermistor
Resolution	± 0.1°C (± 0.2°F)
Control Accuracy	± 0.2°C (± 0.4°F) calibrated
Control Ranges	-17°C to 82°C (0°F to 180°F)
Proportional band for room temperature control	1.8°C (3.2°F)
Proportional band for supply temperature control	28°C (50°F)
Analog 0 to 10 Vdc output	<ul style="list-style-type: none"> 0 to 10 Vdc into 2Kohm resistance min. 5 mA max at 10 Vdc
Vdc pulsed output	20 mA max at 8 Vdc
Power	24 Vac -15%, +10% 50/60 Hz; 2 Va



Viconics Technologies Inc.